

(No Model.)

J. SCOTT.
WOOD TURNING LATHE.

No. 492,112.

Patented Feb. 21, 1893.

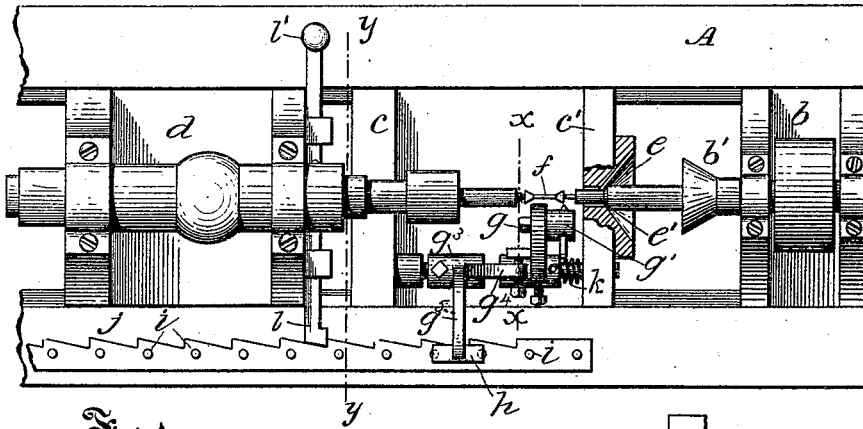

Fig. 1

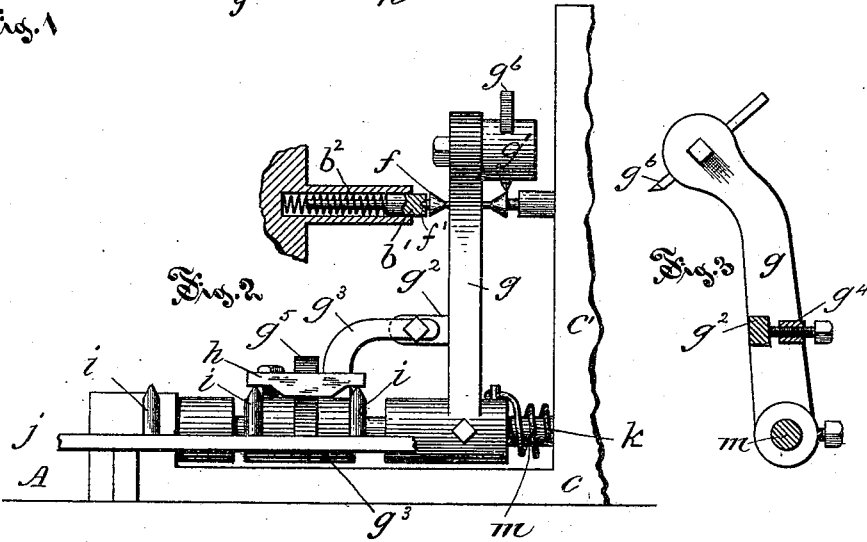

Fig. 2

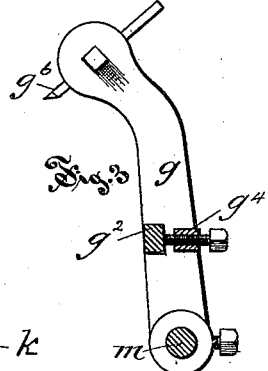

Fig. 3

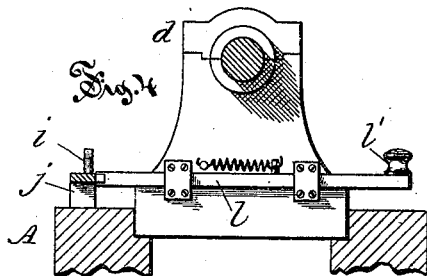

Fig. 4

Witnesses:

W. M. Yorkman
H. R. Williams.

Inventor:

John Scott
By Chas. L. Burdett,
att'y

UNITED STATES PATENT OFFICE.

JOHN SCOTT, OF WILLIMANTIC, ASSIGNOR TO THE WILLIMANTIC LINEN COMPANY, OF HARTFORD, CONNECTICUT.

WOOD-TURNING LATHE.

SPECIFICATION forming part of Letters Patent No. 492,112, dated February 21, 1893.

Application filed August 2, 1886. Serial No. 209,819. (No model.)

To all whom it may concern:

Be it known that I, JOHN SCOTT, of Willimantic, in the county of Windham and State of Connecticut, have invented certain new and useful Improvements in Wood-Turning Lathes, of which the following is a full, clear, and exact description whereby any one skilled in the art can make and use the same.

My invention relates to the class of lathes that are adapted to cut pieces of a given shape in succession from a long blank, and is particularly applicable to a wood turning lathe of the class shown and described in the patent to A. B. Waymouth of June 6, 1876, No. 178,255 and of March 25, 1879, No. 213,718.

The object of my improvement is to provide means whereby shuttle bobbins and like articles may be accurately cut in succession from a long blank, and to this end my invention consists in a former borne on a cutter arm and riding over a succession of pins fast to the lathe bed; in the peculiar connection of the parts making up the cutter arm whereby they are adjustably connected: in the spring depressed former, and in the spring seated arbor for preventing the breaking of the cylindrical barrel of the bobbin, and in details of the combination and arrangement of the several parts as more particularly hereinafter described and pointed out in the claims.

Referring to the drawings:—Figure 1 is a plan view of part of the lathe including the tool carriage, parts being broken away. Fig. 2 is a detail view (in section as to part) in elevation of part of the tool carriage and attachments. Fig. 3 is a detail view on enlarged scale of so much of the cutter arm and immediate connecting parts as lies on the right of the plane denoted by line $x-x$ in Fig. 1. Fig. 4 is a detail view in cross section of the lathe bed and in elevation of part of the front of the tail stock on plane denoted by line $y-y$ of Fig. 1.

In the accompanying drawings the letter A denotes the frame or bed of a wood turning lathe, part only of which is shown in the drawings; b denotes the head-stock that is attached to the upper part of the frame in the usual manner, and supports a live spindle b' that bears a pulley by means of which it may be rotated. The letter d denotes the

tail-stock attached to the upper surface of the frame and adjustable along it by means of any convenient form of feed device; and the letter c denotes the tool carriage supported on the frame and longitudinally movable thereon in ways or guides. These several parts are substantially the same in the main as those shown and described in the Waymouth patents above referred to so that any detailed or extended description of their operation is omitted except as relates to my improvements thereto attached.

The carriage c has at the end next the head-stock an upright flange c' that bears the roughing knife e having a central opening e' in the axis of the lathe, and by means of this roughing knife a blank of irregular form that is held at one end by the clutch in the end of the live spindle b' is reduced to a cylindrical form for a sufficient length to form a bobbin f . The cutter arm g is pivotally connected to the carriage near its back edge so that it has a swinging motion in a plane at right angles to the axis of the lathe spindles, and it bears on its upper end a cutter holder g' that consists of a shouldered block clamped to the upper end of the arm by means of a nut fitted on the threaded end of the shank that projects from the block, and in the opening in this cutter holder g' the cutter g'' is secured with its cutting edge pointing toward the axis of the work, so that when the arm and block are rocked forward the cutter will be projected into the path of the revolving blank. Near the lower end of the arm g , and above the hub through which the pivot or shaft passes is a lug g^2 that projects from the side of the cutter arm g and overlaps the arm g^1 (Fig. 1) that rises from the hub g^3 that is secured as by means of a set screw to the rock shaft on which both this block and the cutter arm are supported. In one of the two overlapping parts a set screw is supported in a threaded socket the end of the screw thrusting against the lug g^2 that projects from the arm g . The arm g is pivotally supported on a shaft and by means of a spring k is thrust normally outward so that the end of this set screw and the lug are held in contact with each other. The function of this set screw is to change the angular relation between the

former *h* that is borne on the outer end of the arm *g*⁵ and the cutter arm *g*. By the adjustment of these two parts with relation to each other the distance to which the cutter *g* will be moved toward the blank by the rising and falling movement of the former *h* may be exactly regulated, and this construction permits the cutting of bobbins of any required diameter within the limits of the adjusting screw that is located between the parts above described. The set screw clearly shown in the several figures of the drawings that passes through the hub at the bottom of the cutter arm may be used to bind the cutter arm firmly on the rock shaft after the proper relation between the cutter arm and the former has been regulated by means of the set screw that passes through the arm *g*⁴. From the hub *g*³ the arm *g*⁵ projects over the lathe bed and overhangs a series of pins *i* that co-operate with a former *h* borne on the outer end of the arm *g*⁵ in determining the operation of the cutter *g*⁶ borne on the outer end of the cutter arm. This cutter *g*⁶ is borne in a lug pivoted to the outer end of the arm *g* said lug being pivotally supported on a bolt passing through the end of the arm into the lug and by means of which it may be clamped in any desired position rotarily thus determining the angle at which the tool *g*⁶ with relation to the axis of the work operated upon. These guide pins *i* are set at intervals along the upper surface of a rack *j* that is secured to the upper surface of the bed A and extends along the bed a distance equal to that traveled by the tail stock. Each of the pins *i* has a wedge shaped point, the sloping sides of the point being in the line of movement of the carriage so that the former *h* rides up and down on each pin, the lower edge of the former is cut in the desired outline to cause the knife to move in toward the axis of the work or out from it, and this former is held down upon the guide pins by means of the spring K, that in the form shown, is a coiled spring located on the shaft with one end thrusting against the pin on the hub of the arm, and the other against the carriage base. On the front of the tail-stock *d* there is attached a spring bolt *l* that is held against the front edge of the rack that is indented or serrated, the form of ratchet teeth shown being preferred. The tail-stock is movable toward the head stock only when this bolt *l* is withdrawn which is effected by an outward pull upon the handle *l'* that is in convenient position for use, and the stock may then be moved up so that the end of the spindle forms a bearing for the front end of the cylindrical blank that has been turned down and pointed to serve as one of the centers of the bobbin to be formed from the blank. It will be noticed that the center of the spindle on the tail-stock is formed of a spring seated plunger *b'* that has a slight lengthwise play and is thrust outward by a spring *b*². The front end of this plunger has a conical socket to receive the pointed end of the blank, and while the blank is thus sup-

ported the carriage bearing the former is fed toward the head stock by any common and convenient mechanism, and in this movement of the carriage the former *h* rides up and down on one of the pins *i* and moves the cutter *g*⁶ against the cylindrical blank at times and to a degree necessary to shape the inner sides of the heads and the barrel of the bobbin *f*. The function of the spring seated plunger is to prevent the breaking of the cylindrical barrel of the bobbin, a result likely to follow the use of the ordinary non-yielding dead center.

By means of a cutting off tool (shown in the patents to Waymouth already hereinbefore referred to), the completed bobbin is severed from the end of the blank of stock forming at the same time the outer end of one of the heads and the cone shaped point *f'* on the end of the blank left in the lathe. This forward movement of the carriage causes the roughing out knife to turn to cylindrical shape a certain length of the blank of stock while the bobbin is thus being formed. The tail stock is again moved up to form a bearing for the outer end of the next bobbin and this operation is repeated until the whole length of blank is used up; the tail stock and tool carriage are then moved to the outer end of the lathe and a new blank of rough stock inserted and the operation of turning the bobbins continued at will.

I claim as my improvement—

1. In a turning lathe, in combination with the head and tail stocks, a tool carriage movable lengthwise of the lathe spindles and bearing a rock shaft upon which a cutter arm is supported, the swinging cutter arm supported on the said shaft and bearing an adjustable cutter, a spring connected to the said cutter arm and operating to normally thrust the latter outward from the work, a block supported on the rock shaft and having a former extending outward from the shaft, and a projecting arm bearing an adjusting screw the end of which thrusts against a projecting part on the cutter arm, the said adjusting screw and a series of pins arranged in the path of movement of the former, all substantially as described.

2. In a turning lathe, in combination with the head and tail stocks, the tool carriage movable lengthwise of the lathe spindles, a series of guide pins secured to the lathe frame and arranged along it in the path of movement of the former supported on the said tool carriage, a swinging cutter arm borne on the tool carriage and supporting an adjustable cutter, the block supported on the rock shaft that supports the cutter arm and adjustably connected to the said cutter arm, and a former borne on an arm that projects from the said block all substantially as described.

3. In a turning lathe in combination with the head and tail stocks, the tool carriage movable in line with the lathe spindles, the rocking cutter arm bearing a cutting tool on

the end next the work, a former block connected to the said cutter arm and bearing on a projecting arm a former overlying a series of pins, the said pins secured to the frame of the lathe and the lathe spindle having the spring seated center, all substantially as described.

4. In a turning lathe, in combination with the head and tail stocks, a carriage movable lengthwise of the lathe spindles, a roughing knife borne on one end of the carriage, and

a swinging cutter arm bearing on the outer end an adjustable cutter and adjustably connected with a former supported on the outer end of an arm borne on the rock shaft that supports the cutter arm and the pins arranged in the path of movement of the former, all substantially as described.

JOHN SCOTT.

Witnesses:

H. R. WILLIAMS,
C. H. ROBBINS.